

TECHNICAL INFORMATION ON CUPOLEX h. 30

RECYCLED POLYPROPYLENE UNIT TO BE USED FOR THE CREATION OF AERATED FLOOR. MODULE 56

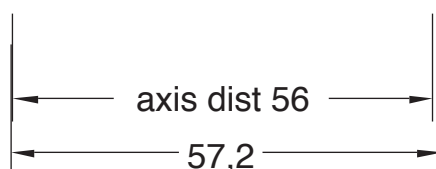
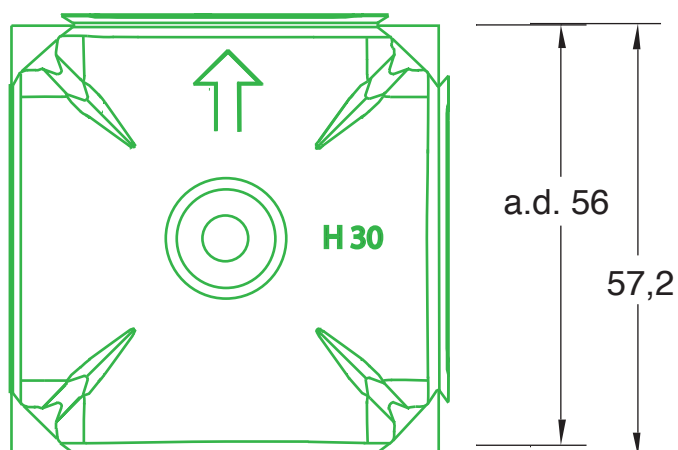
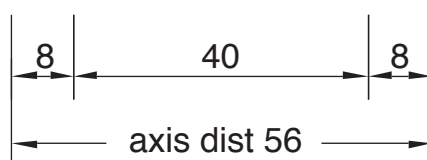
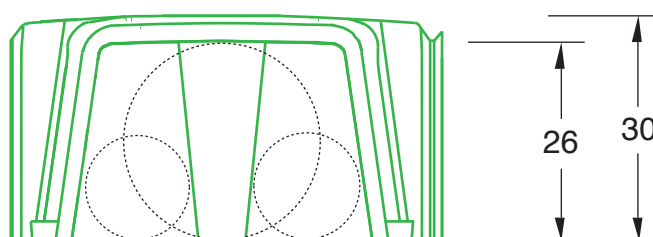

- Concrete consumption: 0,040 m³/m²
- Passing of pipes: n. 2 of 14,5 cm.
n. 1 of 10 cm (cutting the central cone)

ASSEMBLY :

EACH UNIT HAS INSTALLATION ARROWS. COMMENCE INSTALLATION BY STARTING FROM LEFT TO RIGHT IN HORIZONTAL ROWS, THEN GO CHECKING ON JOINTS ON FEET BASE.

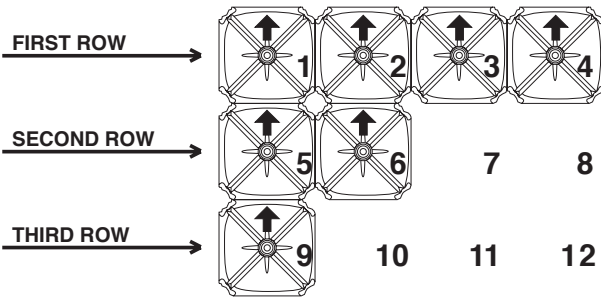

MAKE SURE THAT FEET BASE ARE CORRECTLY INSERTED INTO THEIR SPECIAL JOINTS .

PACKING : ON WOODEN PALLETS WITH CELLOPHANE.

Pallet dimensions	N° of units	Sqm each Pallet	Weight Kg/ unit	Total Pallet (Kg)
120 x 120 h 240	320	100	1,5	490

DIRECTIONS :

- HANDLE WITH CARE WITH GLOVES. AVOID SHOCKS .
- PAY SPECIAL ATTENTION IN USING THE PRODUCT UNDER TEMPERATURE BELOW 0°C OR HIGHER THAN 35°C
- CUPOLEX CAN BE TOTALLY RECYCLED. 

LOAD CHART - DEAD LOAD (KG / M²)

Concrete above Cupolex (cm)	Sub Base (cm)	SOIL BEARING CAPACITY (Kg / cm ²)						
		0.8	1	1.2	1.5	2	2.5	3
3	Native Soil	150	200	300	450	650	900	1000
3	10 Lean Concrete	2000	2400	2600	2600	2600	2600	2600
3	10 Lean Concrete 30 Compact Grav.	2600	2600	2600	2600	2600	2600	2600
4	Native Soil	-	170	275	430	600	900	100
4	10 Lean Concrete	2000	2350	2600	2700	2800	2800	2800
4	10 Lean Concrete 30 Compact Grav.	2800	2800	2800	2800	2800	2800	2800
5	Native Soil	-	150	250	400	600	850	950
5	10 Lean Concrete	1950	2300	2550	2800	3000	3000	3000
5	10 Lean Concrete 30 Compact Grav.	3000	3000	3000	3000	3000	3000	3000
8	Native Soil	-	-	150	350	550	800	900
8	10 Lean Concrete	1900	2300	3200	4000	5100	5100	5100
8	10 Lean Concrete 30 Compact Grav.	5100	5100	5100	5100	5100	5100	5100
10	10 Lean Concrete	2000	2400	3200	4000	4500	5500	5500
10	10 Lean Concrete 30 Compact Grav.	5100	5100	5100	5100	5100	6500	8000
12	10 Lean Concrete	2050	2650	3200	4000	5100	6900	8350
12	10 Lean Concrete 30 Compact Grav.	5100	6800	7750	9750	10000	10000	10000

LOAD CAPACITY

Soil with $k_w = 1 \text{ kg / cm}^3$ and with below 10 cm of Lean concrete .

($k_w = \text{coefficiente di Winkler}$)

BUILDING TYPE	DEAD LOAD (Kg/cm ²)	LIVE LOAD (Kg/cm ²)	SLAB THICKNESS ABOVE CUPOLEX (cm)	WIRE MESH
Housing	200	200	3	diam 5/25x25
Public Building	200	300	4	diam 5/20x20
Garages	300	700	5	diam 6/20x20
Industrial Buildings	300	1200	6	diam 8/20x20

Soil with $k_w = 1 \text{ kg / cm}^3$ and with below 10 cm of Lean concrete + 30 cm compact Gravel.

($k_w = \text{coefficiente di Winkler}$)

BUILDING TYPE	DEAD LOAD (Kg/cm ²)	LIVE LOAD (Kg/cm ²)	SLAB THICKNESS ABOVE CUPOLEX (cm)	WIRE MESH
Industrial Buildings	300	1600	6	diam 8 / 20x20
Industrial Buildings	300	1800	6	diam 8 / 20x20

PONTAROLO[®]
ENGINEERING

Via Clauzetto n°20 Z.I.P.R. San Vito al Tagliamento 33087 (PN)

Tel. 0434 857010 Fax 0434 857014 e-mail: info@pontarolo.com <http://www.pontarolo.com>

The Pontarolo Engineering is not to be held responsible for any mistakes that may contain this document and can make any changes if it see fit without prior notice

M71aREV.1 del 20/01/2005